

## MARS SERIES - GEROLER TYPE

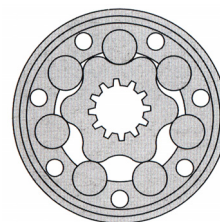

### Features:

Similar to Charlynn "S" series

The MARS Series are GEROLER type 'Low Speed High Torque' Torqmotors. The GEROLER design provides extended life for medium duty applications.

These Torqmotors are suitable for such applications as:

- Conveyor drives
- Winches
- Agricultural machinery
- Forestry machinery
- Cranes
- Sawmill equipment
- Elevators

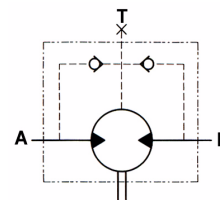

SAE 'A' 2 BOLT MOUNT / 1" KEYED SHAFT	
Part No.	
MARS-50-A-CO-N-U-D	
MARS-80-A-CO-N-U-D	
MARS-100-A-CO-N-U-D	
MARS-125-A-CO-N-U-D	
MARS-160-A-CO-N-U-D	
MARS-200-A-CO-N-U-D	
MARS-250-A-CO-N-U-D	
MARS-315-A-CO-N-U-D	
MARS-400-A-CO-N-U-D	

SQUARE MOUNT 4 BOLT / 1" KEYED SHAFT	
Part No.	
MARS-50-Q-CO-N-U-D	
MARS-80-Q-CO-N-U-D	
MARS-100-Q-CO-N-U-D	
MARS-125-Q-CO-N-U-D	
MARS-160-Q-CO-N-U-D	
MARS-200-Q-CO-N-U-D	
MARS-250-Q-CO-N-U-D	
MARS-315-Q-CO-N-U-D	
MARS-400-Q-CO-N-U-D	

The Above Options are our stock lines, other Shaft and mount option are available for quantity purchase ex the factory.

SEAL KIT	
Part No.	
SK-MARS	

### PERFORMANCE FIGURES

Model	DISP CC/ REV	PRESSURE BAR		FLOW L/MIN		TORQUE				SPEED RPM		WEIGHT Kg
		CONT.	INT.	CONT.	INT.	NM		IN/LBS		CONT.	INT.	
						CONT.	INT.	CONT.	INT.			
MARS-50	51	140	175	40	50	100	128	885	1133	770	970	6.7
MARS-80	81	160	180	60	75	196	221	1735	1956	745	940	6.9
MARS-100	100	160	180	60	75	242	281	2142	2487	600	750	6.9
MARS-125	125	160	180	60	75	271	339	2394	3000	470	600	7.2
MARS-160	159	160	180	60	75	389	428	3443	3788	370	470	7.5
MARS-200	199	135	175	60	75	385	460	3407	4071	300	370	8.1
MARS-250	250	105	160	60	75	388	579	3434	5124	240	300	8.5
MARS-315	315	85	130	60	75	385	570	3407	5045	190	240	9.1
MARS-400	396	65	100	60	75	355	598	3142	5292	150	190	9.5

## MARS SERIES - GEROLER TYPE

**A** Oval Mount SAE.A (2 Holes)

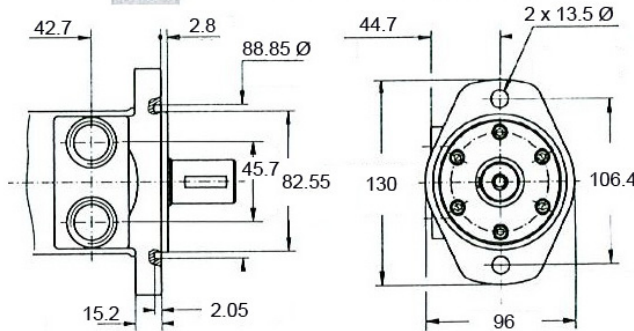

**Q** Square Mount (4 Bolts)

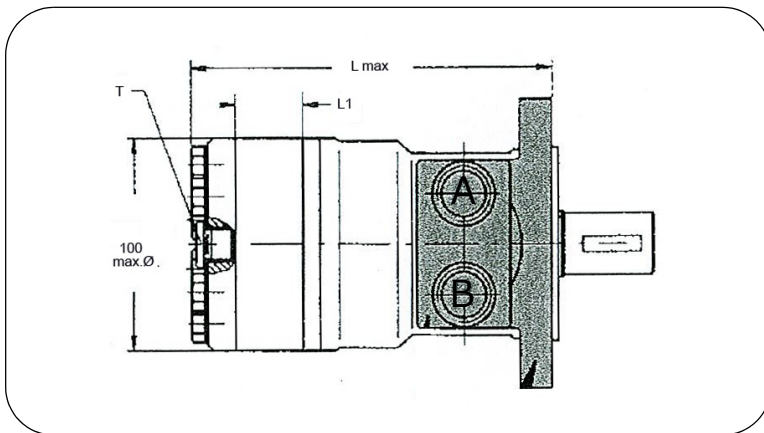
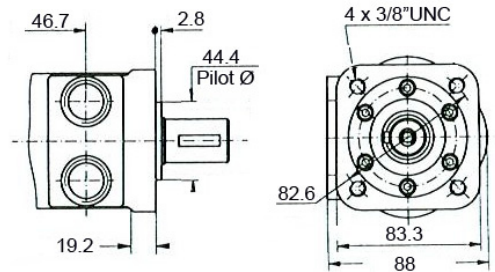

DIMENSIONS		
Model	L mm	L1 mm
MARS-50	144	10
MARS-80	150	16
MARS-100	154	20
MARS-125	159	25
MARS-160	165.5	31.5
MARS-200	174	40
MARS-250	184	50
MARS-315	196	62
MARS-400	208	74

Ports A & B = 7/8"UNO  
 Drain Port T = 7/16"UNC  
 Case Drain required for Series connection

Flow in Port A = Clockwise Rotation  
 Flow in Port B = Counter-Clockwise Rotation

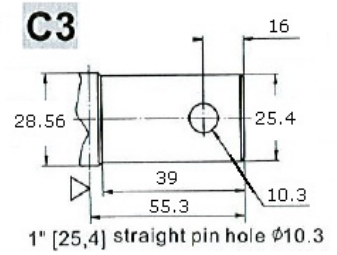
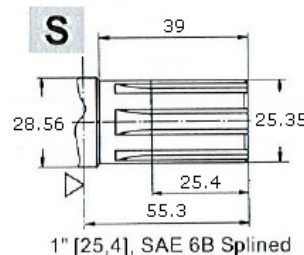
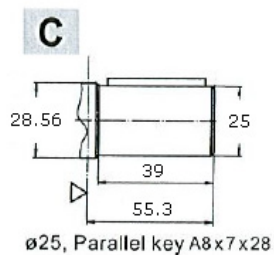
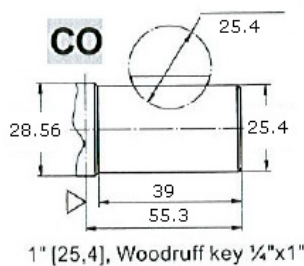

- NB:
- 1/ Intermittent operation values may occur for Max 10% of every minute.
  - 2/ Intermittent speed and intermittent pressure may not occur at the same time.
  - 3/ Recommended filtration to **ISO 4406:1999 Cleanliness Code 19/17/14**.
  - 4/ Recommended operation temperature range is 20°C to 55°C with a Max of 80°C for brief periods.
  - 5/ To assure optimum motor life, fill with fluid prior to loading and run for 1 hour at moderate load and speed.
  - 6/ The hydraulic fluid must be a Premium quality mineral based oil with anti wear additives.