

A Precision 3" Nom. Swage Press for the production of hose assemblies of all types. Designed specifically for portability, with versatile single phase supply. The CS150/220M/SPORT uses Pinless/Push in/Pull Out Dies, enabling change by hand or with optional CS32EQC Quick Change Tool without Press Operation.

Single Button operation where correct installed diameter is achieved, halted then automatic rapid retract to fully open position.

32E Type Dies supplied with Quick Change Containers.

- **2" 4 Wire Hydraulic Hose Capability**
- **3" Industrial Hose Capability**
- **Dies with Colour Coding**
- **Large Aperture**
- **110/220 VAC, 50/60 Hz Worldwide supply**
- **Single Button Operation**
- **Standard swaging range 16 to 55mm diam.**
Extended swaging range 6.5 to 74mm diam.
- **UL and CE approvals**

Dynamic:

Nom. Size (Hydraulic Hose Size Inches).....	2
Die Set Size (mm nom.).....	50-XX/32E-XX
Swaging Range (mm with Std. Die Set).....	16 to 78
(mm with Optional Dies).....	6.5 to 100
Max. Die Set Opening (mm + Die Set Size).....	34
Radial Swaging Force (kN).....	2200
Cycle Speed (Full Stroke-Complete Cycle sec.).....	18

Physical:

Dimensions (Plan mm x mm x Height mm).....	600 x 560 x 520
Weight (Without Dies & Oil kg).....	130
Shipping Space (m x m x m).....	0.385
Shipping Weight (kg).....	170
Crate Size (Plan m x m x Height m).....	0.73 x 0.85 x 0.62

Electrical:

Supply (Volts / Amps).....	110 - 220 / 30 - 15
Phase (No.).....	1
Power (kW).....	1.5
Electric Motor Speed (RPM @ 50 Hz).....	2,880

Hydraulic:

Rated Pressure (bar).....	300
Pump Flowrate (l/min)(No Load).....	6.9
Reservoir Capacity (litres).....	10
Filtration (um).....	100

Installation:

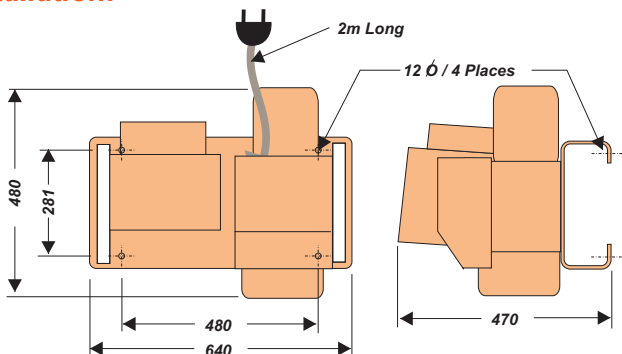

Specifications May Change Without Notice
All Dimensions in Millimeters.

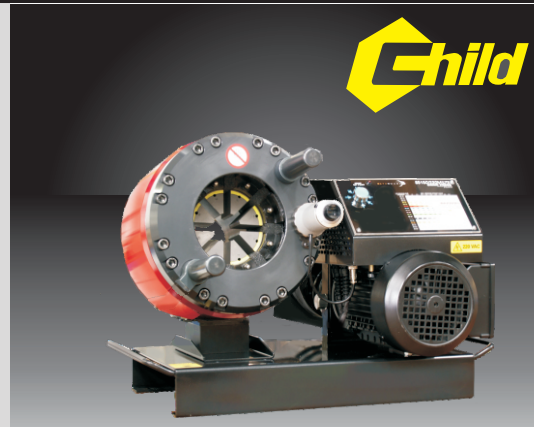
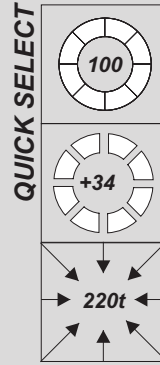

Options:

SP100-32E Spacer Set

The SP100-32E Spacer Set allows for the use of more economical Type 32E Die Sets for swaging diameters less than 60mm. For diameters greater than 60mm, the SP100-32E Spacer Set is removed and Type 32 Die Sets are used.

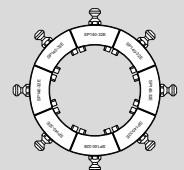

CS32ESDS Standard Die Set

8 Die Sets supplied as a package to allow infinite swaging between 16 to 53mm finished swage size. Each Die Set is supplied in a container that will provide for automatic charging of the CS32EQCT Quick Change Tool.

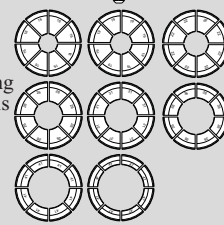

32E- Extended Range & Special Profile

The Extended Range of Die Sets Available are as follows:
 32E-6.5.....6.5 to 8mm finished swage.
 32E-8.....8 to 10mm finished swage.
 32E-10.....10 to 12mm finished swage.
 32E-12.....12 to 14mm finished swage.
 32E-14.....14 to 16mm finished swage.
 32E-53.....53 to 60mm finished swage.



50- Extended Range & Special Profile

The Extended Range of Die Sets Available are as follows:
 50-60.....60 to 68mm finished swage.
 50-68.....68 to 78mm finished swage.
 50-76.....76 to 86mm finished swage.
 50-86.....86 to 96mm finished swage.

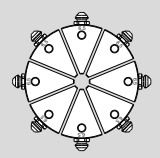

CS32EQCT Quick Change Tool

The Patented Quick Change Tool provides for changing of the Dies in the "Open" state. Therefore not requiring the Swage Press to "Close" & "Open". Dies are supplied in containers that will provide for automatic charging of this tool.

